

## CNC345W20 – 3.0M 20X IP Speedome



### Speedome Function

- 3D Positioning
- Power-Off Memory
- Scheduled PTZ movement
- Park action
- Privacy Mask

### Features

#### Camera

- **3 Megapixel** 2048x1536 @25fps
- **H.265+** Compression
- 20x Optical Zoom
- 16x Digital Zoom
- 120dB **WDR**
- Auto-Iris, Auto-Focus, TDN
- 3D-DNR, Dual Stream
- ONVIF compatible
- Web-server

#### Hardware

- Weatherproof IP66
- 360° Continuous Pan
- Max 120°/s Pan Preset Speed
- Max 120°/s Tilt Preset Speed
- 320 Presets
- 8 Tour (up to 16 presets each)
- 4 Pattern (up to 3min each)
- $\mu$ SD card storage up to 128GB
- 1 Audio In, 1 Audio Out
- 4 Alarm In, 1 Alarm Out
- 6KV Lightning Surge Protection

### Dimension

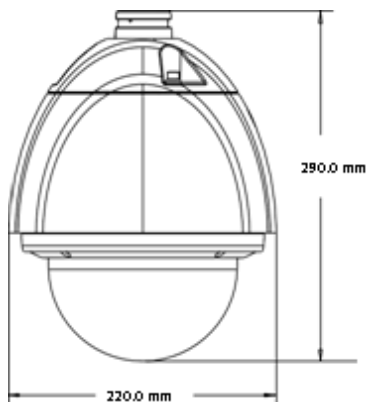

### Accessories



Wall Mount

Corner Mount Wall Mount (with Termination Box)

\* Specification maybe changed without prior notice

# 3000-Series IP Camera



## SPECIFICATION

	Model	CNC345W20
Camera	Image Sensor	1/2.8" progressive scan CMOS Sensor
	Effective Pixels	2048x1536
	Min. Illumination	0.05Lux Color / 0.005Lux BW (F1.6, AGC On)
	S/N Ratio	> 50dB
	Shuttle	1/25 ~ 1/100,100 @50Hz
	Day & Night	Filter Change or TDN (True Day & Night)
Lens	Focal Length	20X (5.5~110mm)
	Aperture	F1.6 ~ F3.5
Mechanism	Pan Speed	0.2~80°/s Manual, 120°/s Preset
	Tilt Speed	0.2~70°/s Manual, 120°/s Preset
	Presets	360
	Tour	8 Tour (Each with max. 16 Presets)
	Park Action	Tour, Scan, Preset
In/Out	Audio	1 Line In / 1 Line Out
	Alarm	4ch in (5~12VDC) / 1 out
Network	Ethernet	10/100 Base-T, RJ45 connector
	Max. Frame Rate	25fps @2048x1536
	Audio Compression	G.711ulaw / G.711alaw / G.726
	Simultaneous Log-in	10
	3-Stream	Support
	SD Storage	Manual / Alarm Rec, up to 128GB
	User Control Level	Up to 32 Users, 3 Level (Admin, Control, View)
General	Working Environment	-20° ~ +60°C, <90° Humidity (Non-Condensing)
	Protection	IP66, 6KV surge protection
	Power	24VDC, Max. 30W (Heater On) / 15W (Heater Off)
	Dimension	220mm(φ) x 290mm(H), 3.5kg

\* Specification maybe changed without prior notice