

CNC-3613MS – 5MP IR Motorized Zoom SMART IP Dome

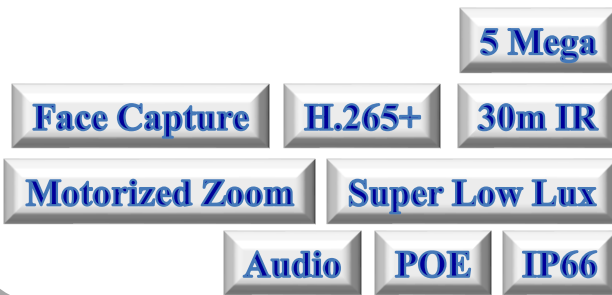

Features

- **5 Megapixel** 2592x1944 @20fps
- **H.265+** Compression
- **3.3~12mm Motorized** Zoom Lens
- **Auto Focus**
- **True WDR**
- 3D-DNR, DSS, BLC, HLC, Defog, ROI, 3-stream etc
- **Super Low Lux**
- LED Array, 0 Lux up to 30m
- Audio In, CVBs out
- uSD Slot up to 128G
- POE / 12VDC Dual Power
- IP66 Weatherproof

SPECIFICATION

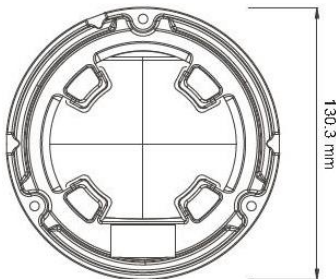
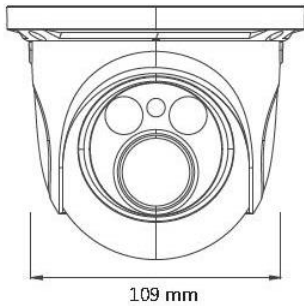

Model	CNC-3613-MS
Image Sensor	1/1.8" progressive scan CMOS Sensor
Resolution	2592x1944@20fps (PAL)
Shuttle	1/25s ~ 1/100,000s
Lens	M14 3.3-12mm Motorized Zoom Auto Focus
Viewing Angle	80°~38°
LEDs	2nos 850nm IR LED Array
Day & Night	Filter Change or TDN (True Day & Night)
Min. Illumination	0 Lux up to 30m (Subject to reflection)
Network	10/100-BaseT, RJ45
Bit Rate	64Kbps ~ 10Mbps
Compression	3-Stream : H.265 / H.264 / MJPEG
Working Environment	-20° ~ +50°C, <90° Humidity (Non-Condensing)
Power	POE IEEE 802.3af compliant/12VDC, Max. 6.5W
Dimension	109mm(φ) x 110mm(L), 0.9 kg