

IGS-208-PS – 8-GB-POE + 2-GB-SFP Industrial Switch



(SFP Fiber Optic Module Not Included)

Features

- **8x 1000Mbps POE** Device Port
- **2x 1000Mbps SFP** Uplink
- **Fast Ring** by Dip Switch
- <20ms Recovery
- **20Gbps** switching capacity
- POE+ 30W /port
- POE & Communication LED indication
- Surge Protection : 6KV, 50000h MTBF
- Industrial Grade with DIN Rail mount
- **Relay** output
- **12 ~ 48VDC** Input

Connection Diagram

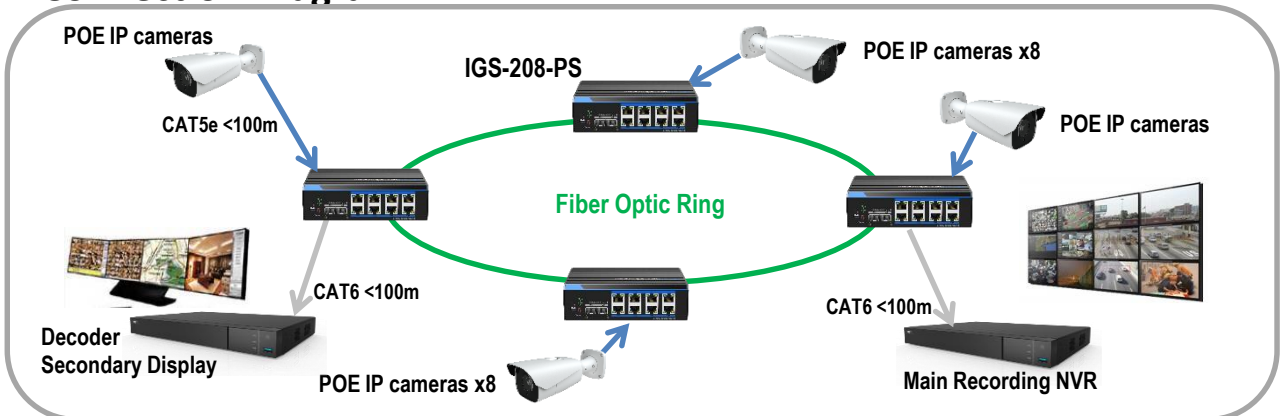

Specification

- 12VDC-48VDC (Adapter Inc.)
- Network Standard : IEEE802.3/u/ab/x/z
- POE Protocol : 802.1 D/at/af
- Packet Forward Rate : 14.9 Mpps
- MAC table : 16K
- Memory Buffer : 2MB
- Surge Protection : 6KV, IEC61000-4-5
- Power Consumption : 12W (not inc. POE)
- Operating Environment : -40~75°C / 0~95% Humidity
- Aluminum Casing with Black Epoxy Powder Coating
- Size : 159(W) x 110(D) x 46.5(H) mm
- Weight : 0.932kg

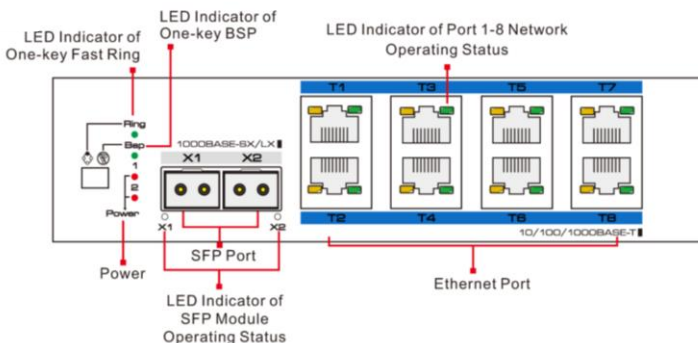

* Specification may be changed without prior notice